

PDD-8PCI INSTRUCTIONS

PDD-8PCI DC Power Distribution with Supervised Interface module

Distributed Power Control Interface for Fire, Access, HVAC, Elevator, and Security



Features:

- 8 class II Power Limited Outputs with Auto-Resetting Circuit Breakers
- Each Output is Individually Selectable to Turn On, Turn Off, or always ON when Triggered
- Outputs can be triggered with:
 1. Voltage or Reverse polarity (opto isolated)
 2. N/O or N/C switch with supervised EOL
- Form C Contacts (TRIGGERED) and Red LED (TRG) Indicate Trigger Status
- Form C Contacts (TROUBLE) and Green LED (TRB) Indicate:
 1. One of the output circuit breakers is tripped
 2. Main Fuse Blown or no power on input
- Universal 11-29VDC Operation
- Each Output pair has a Removable Terminal Block
- Each Output has a Green Status LED
- Main Power has Green Status LED
- Main Power Pull and Fuse
- Lifetime Warranty
- UL Listed Sub Assembly for Access Control and Burglar alarm systems

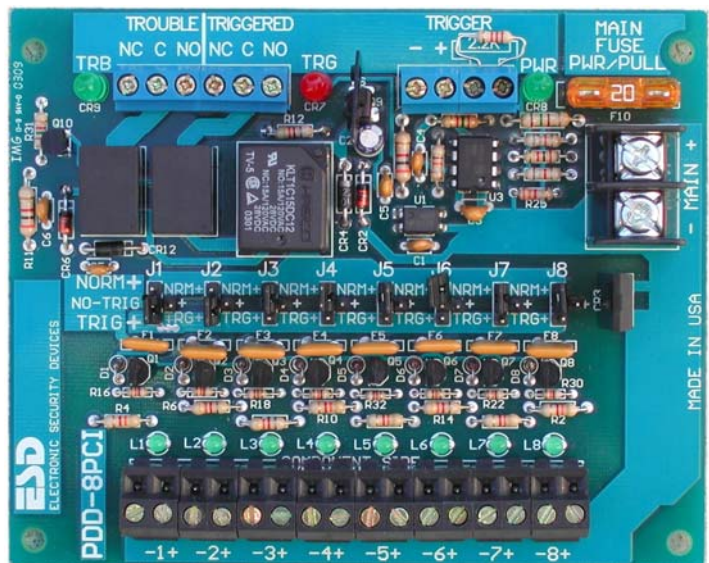

Description

The PDD-8PCI power distribution control interface converts a main non-power limited DC power source to 8 class II power-limited outputs that can be controlled by a (FACP) Fire Alarm Control Panel. Each output can be selectively set (J1-J8) to turn ON or to Turn OFF when triggered by the panel. The FACP or other control system can interface to the PDD-8PCI with either of two or both supervised trigger inputs. One trigger is activated with a reverse polarity voltage from a FACP. This trigger is fully isolated with an optical isolator. The other trigger is an (EOL) 2.2K End Line Resistor input which will accept a (N/O) Normally Open switch or a (N/C) Normally Closed switch.

When triggered, the Trigger Transfer Relay removes power from the NORM + buss and transfers it to the TRIG + buss. Jumpers J1-J8 determine which buss each output is connected to. The triggered form C contacts also drop off normal when triggered and the Red (TRG) LED turns on. These contacts can be used to daisy chain other PDD-8PCI, latch, or provide feedback to a system.

The Trouble Form C Relay drops off Normal if any one of the PTC circuit breakers is tripped, or main power/fuse is lost. The Green (TRB) LED is ON during

normal operation, it goes off with trouble. All three relays are Fail-Safe, energized in the normal condition.

Each output has a Green LED that is on when the associated output is ON.

Typical applications for a Fire Alarm System would include adding remote Bells and annunciators, closing dampers, turning off HVAC fans, unlocking fail secure and fail safe doors, and or returning elevators to first floor. The installation instructions illustrate these applications.

The PDD-8PCI is available as a module or mounted in an enclosure with any of our DC Power Supplies.

Specifications

Input Voltage	11–28VDC
Current, Typical, with No Output Load	90-160mA
Outputs 1–8 continuous duty each	1.23 Amps
Voltage Trigger	20% < Input min. 30vdc max.
Voltage Trigger isolation	Optical
EOL (End of Line) Trigger	Trip +50% of 2.2K Ω
Transfer Relay Contacts	15Amps
Trouble Form C Contacts	2A 120vac/1A 220vac
Triggered Form C Contacts	2A 120vac/1A 220vac



Electronic Security Devices
2200 N MacArthur Drive
Tracy, CA 95376

01/13/09 © Technical Literature jdb PDD-8PCI Installation specifications subject to change
lproducts\pdm-Interface\pdd8PCIInstallation.doc

Manufacturers of High Quality Security Devices

Phone: (209) 229-7140 Fax: (209) 229-7145
ESD@SecurityPower.com www.SecurityPower.com

Explanation of Terminals:

(-MAIN+) Main DC power input. Observe polarity 11 – 30 DC volts. The input voltage will be the voltage on the output. Power limiting is not required. If the DC input is not power limited, the non-power limited wires must maintain a minimum distance of ¼” from the power limited outputs. Input wires should be sized appropriately for total load. This terminal block can accept multiple wires from 10awg to 24awg. Input wiring and power must be suitable for the total output load. As you might expect we recommend an appropriate **ESD** Power Supply for main power.

(- 1 + through – 8 +) Triggerable outputs 1-8. Each of these paired output terminal blocks is un-pluggable for easy service. These outputs are class II power limited. Each output is rated at 1.23Amps continuous duty. Each output is protected by a PTC circuit breaker. If a PTC is tripped, the load must be unplugged or removed for up to 1 minute for the PTC to cool and reset. Whether these outputs are normally ON or OFF, is determined by J1 – J8 jumpers. See Jumpers explanation. Terminal blocks can accept 14awg – 26awg wire.

(Trigger Input EOL) End of line resistor terminal pair. When the 2.2K EOL resistor changes by more than 50% due to an open or a short, the Trigger is activated. If not using this trigger, leave the 2.2K EOL resistor on the terminals to keep this trigger at normal status.

(Trigger Input -DC+) A DC voltage between 11 and 30vdc applied to this terminal pair with the indicated polarity will activate Trigger. Figure 1 shows this input connected to the signal devices of a Fire Alarm Control Panel. When the signal devices ring, the PDD-8PCI is Triggered. This input is fully isolated with an optical isolating relay. Terminal blocks can accept 14awg – 26awg wire. The minimum input voltage for this trigger is 20% less than the main input supply voltage.

(Triggered Output NC C NO) Three terminals, form C relay contacts drop off normal when triggered. The NC and C contacts are normally closed, and then open when triggered. Terminal blocks can accept 14awg – 26awg wire.

(Trouble Output NC C NO) Three terminals, form C relay contacts drop off normal when there is Trouble. The normal state is energized with no fault. If any one of the output PTC circuit breakers trip or the main power is lost from main fuse or otherwise, the trouble contacts will drop off of normal to Trouble. Terminal blocks can accept 14awg – 26awg wire.

Explanation of LED's and Jumpers:

(Jumper J1 through J8) J1 through J8 is associated with outputs 1 through 8. Each jumper determines normal state of associated output. If jumper is moved up beside (NORM +) then that output will be normally ON. When Trigger is activated, that output will be off. If the jumper is moved down beside (TRIG +) then that output will be normally OFF. When Trigger is activated, that output will be ON. On the 4 pin models, when Jumper is placed on the middle 2 pins in a horizontal position, the trigger will be disabled and the associated output will be active ON all the time.

(L1 through L8) Green LED's above each output pair indicates when each output is ON.

(TRB) Green LED normally ON. LED OFF means Trouble fault. 1 of the outputs has a PTC circuit breaker tripped, main fuse blown, or no power.

(TRG) Red LED ON when PDD-8PCI is triggered from either trigger input.

(PWR) Green LED normally ON. If power LED is OFF, it would indicate Main Fuse is blown or no there is no input power.

Installation Instructions:

1. Mount module or system in an appropriate location.
2. Keep a minimum space of ¼” between any Non Power Limited wires and the Power limited outputs of this device.
3. Connect the DC of the power supply to the terminals marked (-MAIN+)
4. Set Jumpers J1 – J8.
5. Connect security devices to the proper outputs as have been set with J1 – J8.
6. Connect trigger input. To trigger the PDD-8PCI from a FACP connect signaling circuit of FACP to inputs marked (-) and (+). Such that when the FACP is in alarm it would trigger the PDD-8PCI.
7. To trigger the PDD-8PCI from a Normal Open or Close switch, open or short the end of line resistor as shown in the application diagrams. If this trigger is not used, you must leave the EOL resistor connected so this input will not trigger allowing the voltage trigger input to be operational.

8. If applicable, connect Triggered Output contacts. These contacts can connect to Auxiliary devices to indicate unit is triggered. NC means Normally Closed in the normal, energized condition, not triggered condition. C and NO will close when unit is triggered.
9. Connect Trouble Output contacts. NC means Normally Closed in the normal, good energized condition. C and NC will open with trouble.

Application Diagrams:

Note: To latch additional PDD-8PCI's, you could use an output that would apply voltage to the next card's voltage trigger input.

Fig. 1 - Showing Terminals, LED's, Trigger Selectors and Layout.

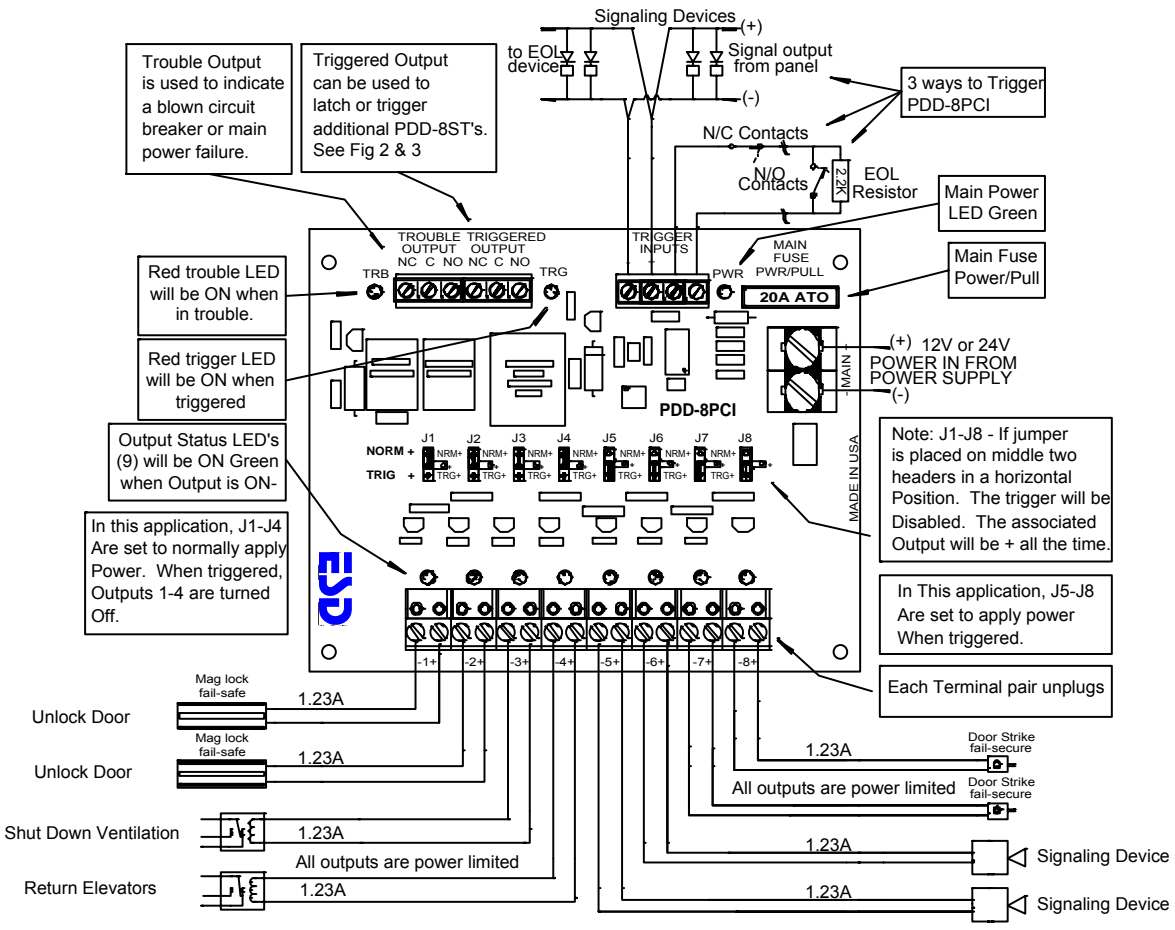

Fig. 2 - Latching Application with N/O Manual Reset.

In this application, the Triggered Output contacts are fed back to the Trigger Input, latching the trigger until reset with the N/O contacts.

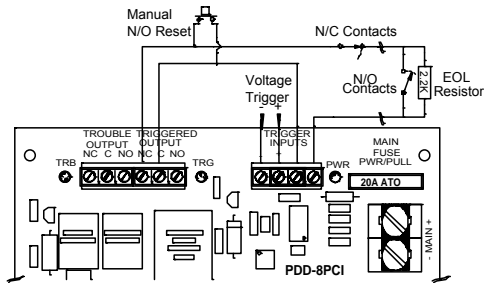

Fig. 3 - Latching Application with N/C Manual Reset.

In this application, the Triggered Output contacts are fed back to the Trigger Input, latching the trigger until reset with the N/C contacts.

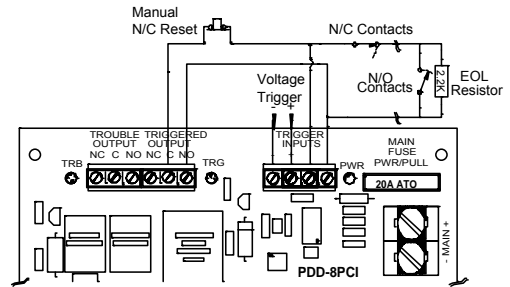
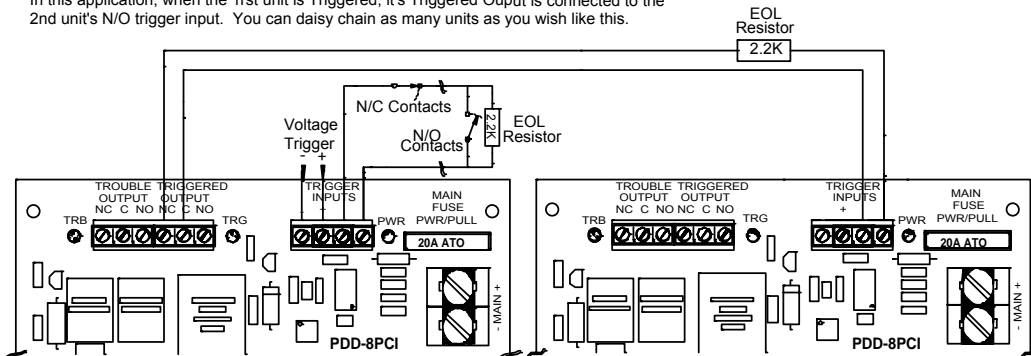

Fig. 4 - Triggering multiple PDD-8PCI's. Non Latching.

In this application, when the 1st unit is Triggered, it's Triggered Output is connected to the 2nd unit's N/O trigger input. You can daisy chain as many units as you wish like this.



Put Your Application Here: